

KARAVAN

Enclosed are the operating instructions and warranty information for your new Karavan Trailer. Please review carefully before operating.

OWNER'S MANUAL



UTILITY



Product and specifications subject to change without notice.

Table of Contents

General Warranty Informaton	1
Ball Coupling/Brakes	3
RAM Coupler Instructions	4
Hubs, Bearings, Races & Seals	5
Lighting & Wiring	9
Maintence	11
Load Capacity & Wheel Information	12

IMPORTANT

Read this manual carefully with special attention directed towards all WARNING, CAUTION and IMPORTANT information specially marked. Because of the continual improvements being made in our line, Karavan Trailers, LLC., reserves the right to add or discontinue models at any time or to change design and specifications without notice and incurring obligations. All specifications contained herein were in effect at the time this manual was printed. Trailer laws covering such things as brakes, licenses, etc., will vary from state to state. Be sure that your trailer is in full compliance with your state laws. Your trailer dealer usually can help you in this regard. If not, contact your nearest state motor vehicle department office for full information. The key to carefree trailering is a proper matching of the trailer to your needs. A proper match is one in which the total weight and size of the load you intend to haul falls under the capabilities that your trailer was designed and built to handle.

Note

All references to the left or right are made when standing behind the trailer, facing the trailer.

Karavan Trailers, LLC. Limited Warranty Policy

Please register your trailer online at www.karavantrailers.com

A complete Owner's Manual is available online

Contact us at: warranty@karavantrailers.com or 920-928-6411

Karavan Trailers, LLC. warrants each new **Karavan Trailers** trailer to be free from defects in materials and workmanship for a period of one (1) year from the date of purchase. **Karavan Trailers** shall repair or replace, without charge, any parts found to be defective because of imperfect workmanship or materials, within a reasonable time after the trailer is returned at purchaser's expense to any **Karavan Trailers** authorized distributor or dealer.

Who is covered?

This warranty is extended to the original purchaser only.

How do I make a claim?

1. Your claim must be filed on the Karavan website at: <http://www.karavantrailers.com> or in writing to: Karavan Trailers, Inc., 100 Karavan Drive, Fox Lake, WI, 53933.
2. Claim must provide true and complete information when filed.
3. You must cooperate with Karavan when attempting to resolve the claim.
4. Only Karavan and authorized dealers may be used to fulfill the warranty claim.
5. Karavan may elect to repair or replace your product, or in some cases, offer you a refund.
6. Karavan will inform you whether your claim is covered by warranty within thirty days of receiving the trailer.
7. Any disputes must be resolved in state or federal court.

What is not covered?

Although you may use the parts and maintenance, and repair services of your choosing, we recommend using authorized dealers and parts for any repairs or maintenance, because improper or incorrect use of parts, maintenance, or repairs will void this warranty. Authorized parts are recommended for replacement of winches, lights, couplers, brakes, tongue jacks, and springs. Authorized dealers are listed on the Karavan website.

The warranty will not cover defects or damage caused by unauthorized modifications or alterations.

The warranty does not apply to any defect or malfunction caused by damage, unreasonable use, or failure to provide reasonable and necessary maintenance.

The warranty will not cover damage caused by overloading the trailer beyond stated capacities or the use of improperly installed weight distribution hitches in conjunction with hydraulic surge brakes.

Rust formation is not covered because the trailer is exposed to highly corrosive conditions.

Tires are not covered. Warranty on tires shall be made through the nearest tire representative.

Bearing cups, bearings and seals are covered for 180 days from date of purchase.

The use of any unit as part of a rental fleet or use for commercial purposes voids this warranty.

Other Limitations

Any implied warranties, obligations, or liabilities including, but not limited to, any implied warranty of merchantability or implied warranty of fitness for a particular purpose, shall be limited in duration to the one-year duration of the written limited warranty.

Karavan Trailers, LLC. shall not be liable for incidental expenses of the consumer including, without limitation: loss of time, inconvenience, towing charges, travel expenses, lodging, telephone, gas, or loss or damage to personal property or loss of wages.

Karavan Trailers, LLC. shall not be liable for any incidental or consequential damages for breach of this or any other warranty expressed or implied.

This warranty gives you specific legal rights, and you may also have other rights which vary from State to State. Some States do not allow limitations on how long an implied warranty lasts, and/or the exclusion or limitation of incidental or consequential damages, so the above limitation or exclusion may not apply to you.

Karavan Trailers, LLC. will follow any controlling warranty laws for trailers purchased in countries outside the United States.



Brakes

In most states, trailers with a Gross Vehicle Weight Rating of 3,000 pounds or more are required by law to have brakes on all wheels. Upon special request, you can order axles with brake flanges to be able to install brakes. Brakes are becoming more of a necessity especially since the introduction of the small size car.

Most trailer brakes are designed to operate automatically when the towing vehicle's brakes are applied. When the towing vehicle slows down or stops, the forward momentum of the trailer against the ballhitch applies pressure to a master cylinder in the trailer coupler. This pressure activates the trailer brakes through a hydraulic brake system.

CAUTION: Weight equalizing or sway control devices inhibit the performance of surge brake actuators and must not be used. Air shocks on the rear axle of the tow vehicle offer a good means of leveling the vehicle and trailer when necessary.

Reporting Safety Defects

If you believe that your vehicle has a defect that could cause a crash or could cause injury or death, you should immediately inform the National Highway Traffic Safety Administration (NHTSA) in addition to notifying Karavan Trailers, LLC. If NHTSA receives similar complaints, it may open an investigation, and if it finds that a safety defect exists in a group of vehicles, it may order a recall and remedy campaign. However, NHTSA cannot become involved in individual problems between you, your dealer, or Karavan Trailers, LLC.

To contact NHTSA, call the Vehicle Safety Hotline toll-free at: 1-800-327-4236 (TTY 1-800-424-9153), <http://www.safercar.gov>; or write to: Administrator, NHTSA, 1200 New Jersey Avenue S.E., Washington, DC 20590

You can also obtain other information about motor vehicle safety from <http://safercar.gov>.

BALL COUPLING

WARNING: The installed ball coupler **MUST** be properly secured to the hitch ball of the towing vehicle. After assembly and attachment, pull up and down on the ball coupler to make sure the hitch ball is fitting snugly on the hitch ball. There must be no play between the hitch ball and ball coupler. If there is play, tighten the adjustment nut until no play is present. If the adjustment nut is too tight, the handle will not lock.

If the ball coupler is not secured properly, it could come lose while the trailer is in motion, possibly causing property damage, **SERIOUS PERSONAL INJURY** or **DEATH**.

CHECK BALL COUPLER TIGHTNESS OFTEN



Lever Latch Coupler Repair Installation Sheet

WARNING:

Carefully read and understand below instructions for safe installation of the RAM lever latch repair kit. Failure to follow these instructions and basic safety precautions may result in serious personal injury. For coupler installation to trailer and coupler maintenance refer to the RAM coupler installation/maintenance sheet that can be supplied upon request.

Lever Latch Parts

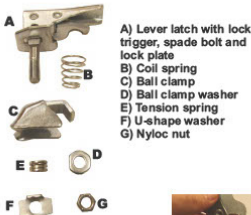

Step One - Slide lever latch (in open position) spade bolt through coupler hole just behind coupler ball pocket. Keep lever latch in open position.

Step Two - Slide coil spring up over the spade bolt. Larger opening end of coil spring is to face upward to come in contact with underside of coupler.

Step Three - Slide ball clamp up on spade bolt with cupped part facing upward and toward coupler ball pocket. Back lip of ball clamp is to be up and over the coupler re-inforcing bar.

Step Four - Slide ball clamp washer on the spade bolt with the flat side of washer facing forward.

Step Five - Slide tension spring on the spade bolt.

Step Six - Slide U shaped washer on the spade bolt. Make sure the washer remains in this orientation.

Step Seven - With the lever latch in an open position tighten nyloc nut. (A flat head screw driver can be used to push the u-shape washer up so nut can be tightened.)

Periodically as you are tightening the nut remove the flat head screw driver and close the lever latch on the coupler with the proper size hitch ball in the coupler ball pocket. Keep doing the tightening process until closing the lever latch is difficult. At this point the ball clamp should be resting very snug against the hitch ball. At this point open the lever latch and loosen the nut a half to three quarter turn. Close lever latch again (lever latch should close with less resistance) and hitch ball should be able to pivot inside the coupler ball pocket.

Once instructions above are completed, coupler is adjusted properly and coupler is in the closed/engaged position the bottom of coupler and proper size hitch ball in the coupler ball pocket should look like photo to right. It is important that the u shape washer remain in this orientation. Also after coupler is properly adjusted there should never be less than a full thread exposed on the spade bolt below the bottom of the nut.



RAM Trailer Products
19120 SE 34th Street, Suite 105
Vancouver, WA 98683
Ph: 360-859-3828

Hubs, Bearings, Races and Seals

Karavan Trailers uses the following sizes of hubs on all of its model trailers. Measurements listed are both spindle size and hub size.

Hub Size	Bearing, Race & Seal Size	Manufacturer's Number
1-1/16"	Inner & Outer Bearing 1-1/16"	L-44649
5-1/2" flange	Inner & Outer Race 1-1/16"	L-44610
	Spring loaded dust seal (1.250 I.D.-1.985 O.D.)	12192 TB
	Dexter Torsion Axle	
Chevron Starplex EP2	Spring loaded dust seal (1.500 I.D.-1.985 O.D.)	15192 TB
1-3/8"-1-1/16"	Inner Bearing 1-3/8"	L-68149
5 Bolt UHI	Inner Race 1-3/8"	L-68110
10" Brake Drums	Outer Bearing 1-1/16"	L-44649
	Outer Race 1-1/16"	L-44610
	Spring loaded dust seal (1.750 I.D.-2.565 O.D.)	17255 TB

Grease Seals

Inspect the grease seals periodically. A visual inspection is sufficient and is done quite easily on a trailer without brakes. It is normal to see a small oil film around the seal area. This should not hurt anything. However if the leakage becomes excessive it is time to replace the seal before too much grease escapes causing bearing failure. Replacement of the seal requires removing the complete hub assembly from the spindle.

On axles with brakes you must remove the complete brake drum assembly to inspect the seals. It is very important that you check the seals on brake axles periodically to make sure they are not leaking. Leaking seals allow the grease to get on the brake linings thus causing grabby brakes. Eventually the brake linings will become saturated with grease and will have to be replaced.

****Please note** that some Karavan Trailer models are equipped with Knott-AutoFlex Waterproof bearings that require no maintenance. DO NOT remove the metal cap for any reason or damage could result to the bearings. The caps have KNOTT- WATERPROOF stamped in them.

Karavan's Sure Lube System

Karavan uses a Sure Lube system on all of its axles. This system is a well accepted benefit for trailering. Under the rubber dust cap there is a grease zerk. The grease zerk presses into the hole that goes all the way through the center of the spindle and comes out by the back bearing. At that point it greases the back bearing and fills the inside of the hub. It then greases your front bearing. When you see grease come out by the castle nut, your hub and bearing are full.

Advantages of the Sure Lube System

1. You can grease the bearings without taking the hubs off.
2. You can change the grease in your hub and bearings by rotating the hub slowly while putting grease in, until you see new grease come out.
3. You can check your hub & grease at any time.
4. You can grease your bearing at any time on long trips.

Maintenance of Sure Lube

1. Once or twice a year (depending on usage) jack your trailer up one wheel at a time. Hold the wheel with both hands and try to rock to check for play in the bearing. If you have play then you need to adjust your castle nut (see bearing adjustment).
2. When greasing bearings look at the old grease when it comes out. If you see small silver like filings it may indicate a problem with your bearings. They should be replaced immediately.
3. It is important to use a pin the same size as the hole to make your Sure Lube system work properly.

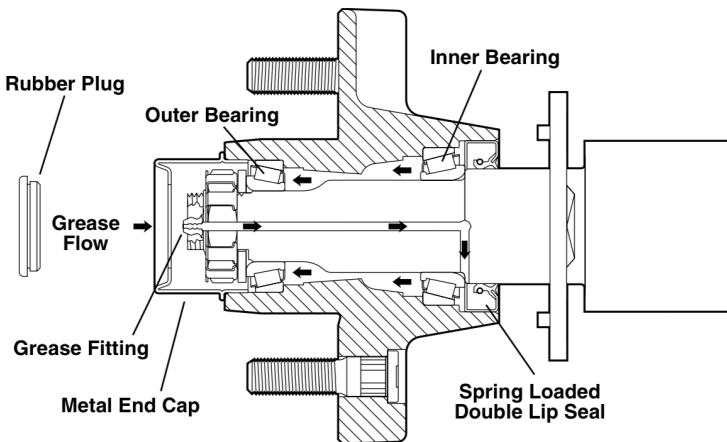

When to Check

Trailers often sit idle for extended periods of time so it is a good idea to check all of these before any use. Bearings rechecked and repacked before storage.. and after immersion in salt water will last longer. Check the lubricant level when the hub is warm. On boat trailers, we suggest that you check just prior to launching to be sure the hub is full of grease when the axle is submerged.

Recommended Lubricant

Chevron Starplex EP2 Grease is installed at the factory. Any good marine grade water-resistant grease is recommended. Different types of grease thickeners should not be mixed.

Bearing Repacking

Ideally, one would not have to be concerned about wheel bearings in that you would not have to get them submerged in the water when loading and unloading. This is not the case in many instances so therefore preventative maintenance is required. This type of maintenance varies so greatly because one individual may back his trailer in and out of the water 300 times a year and tow it 1,500 miles total while another individual may back his in the water six times a year but tow it 7,000 miles. Then we also have an individual that hauls his boat 30 miles, puts it in the water for the summer, and then loads it back up in the fall for the 30 mile trip home.

Because of the various types of ways in which people use a trailer it becomes difficult to say every 500 miles repack your bearings or after backing in the water 10 times repack your bearings. Neither of the above can apply. About the only thing that applies is good common sense.

Note the following:

1. When water gets in the bearings and is on the steel itself it will rust. So the most important part is get a good grade of wheel bearing grease that will not break down when water is mixed with it.
2. Pack the bearings by forcing the grease into all the small cavities in the bearings. Fill the cavity in the hub with grease.
3. Make sure the grease seals are in usable condition.
4. Keep the bearings and grease free of any dirt or foreign matter.
5. The wheel bearings should be repacked anytime during the year that you plan on storing the trailer for a period of time.

6. The more often you back your trailer in the water, the more chance you stand of getting water in the bearings. You should definitely be packing your bearings more often (at least twice during the season) if this is the situation.
7. Towing a trailer numerous miles has its good points and bad points. Long tows may warm the hub and grease up enough to remove any water it may have collected. However should you then back the warm hubs into the water just after a long tow they will take on water through condensation. It is therefore important that you let them cool before backing into the water.
8. Be sure the bearings are adjusted properly not too tight, or too loose. See Bearing Adjustment.

Check the grease in your hubs once a year. In most instances, if a good quality lubricant is used and the lubricant levels are maintained, it may not be necessary to repack the bearings. However, should the grease appear to be contaminated or broken down, remove all of the old grease from the bearings and hubs and completely repack. Remove the rear bearing will most likely cause damage to the rear seal. A new one should be installed when reassembling.

Bearing Adjustment

The wheel bearings have been preadjusted at the factory. To maximize bearing life, however, we suggest that you check the bearing adjustment after the first 50 miles of use, then every time the bearings are repacked.

Bearing adjustment can be checked by jacking up one side of the trailer. Grip the edge of the wheel and see if you can rock it or move it. If you have movement remove the dust cap and the cotter key. While rotating wheel tighten the spindle nut to a recommended 20 inch-pounds of torque if your trailer has 1-1/16" - 1-1/16" bearings or 30 inch-pounds if your trailer has 1-3/8" - 1-1/16" bearings. Do not over tighten. Look for the hole in the spindle through the slots in the spindle nut. If you can see any part of the hole through the slot in the nut, turn the nut counterclockwise until the next slot in the nut lines up with the cross hole. Insert cotter key or new L pin.

If you cannot see any portion of the hole in the spindle through the slots in the nut, turn the nut counterclockwise until the hole lines up with the first slot available in the nut. Insert cotter key or L pin. This adjustment will give you from one-thousandths to ten thousandths end play, which is in tolerance for proper adjustment. Check wheel again for the movement. If no movement, spin wheel. Wheel should turn easily and have no end play (lateral movement). Bend ends of cotter key or L pin to keep it from coming off. A large cotter pin must be used to fill the hole for the sure lube system to work properly. Position dust cover. Tap lightly on edges to start cover. Then using a screwdriver and alternating sides as you work around the dust cover, tap screwdriver with hammer until the dust cover is completely into the hub and the flange on the dust cover is tight against the hub face. Repeat on other wheels.

Lighting & Wiring Diagram & Color Code

Make sure that all trailer lights are in proper working order.

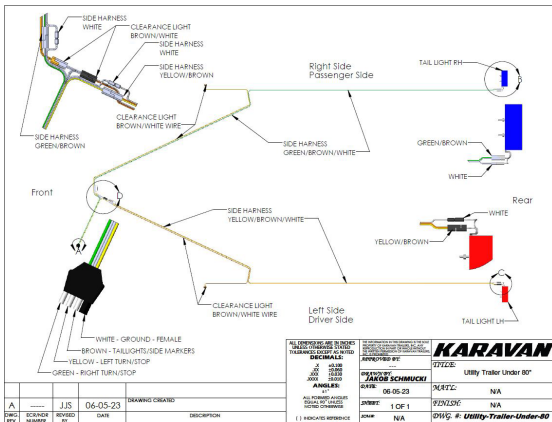
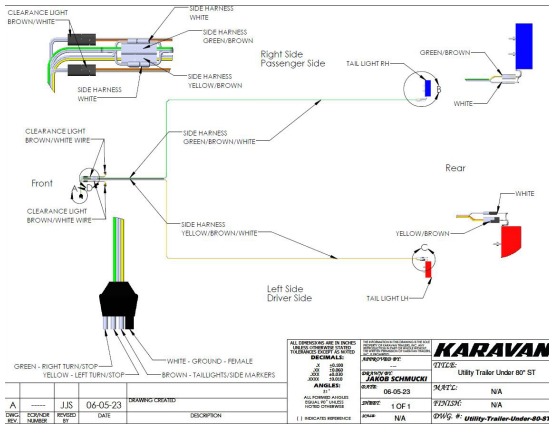
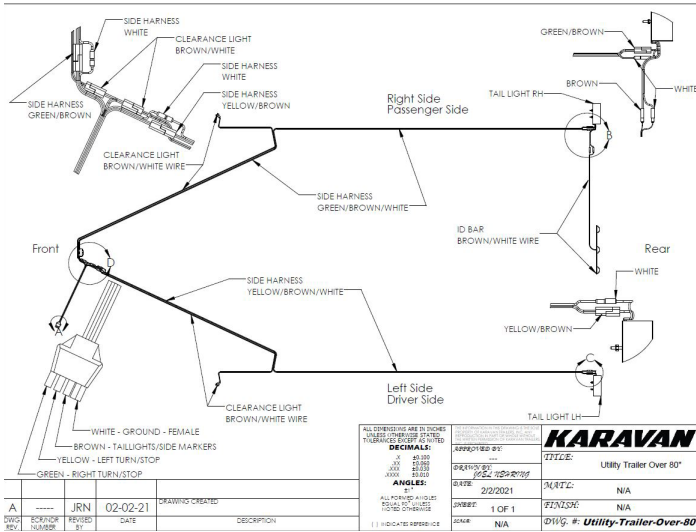

Yellow Wire - Left Stop & Turn

Green Wire - Right Stop & Turn

Brown Wire - Taillights, Rear Marker Lights, Front & Rear Side Lights

White Wire - Ground

State and Federal regulations require all types of trailers to be equipped with tail, stop, turn and side marker lights. Trailers over 80 inches wide must have clearance and identification lights. All the necessary lights are supplied by us, the manufacturer, however it is the owner's responsibility to maintain them in good operating condition at all times.

Make sure the ground wire is attached to both the trailer and towing vehicle to make a sure, positive ground. Some towing vehicles are equipped with a 4-wire taillight systems. It then becomes necessary to use a four to a three wire converter.

Troubleshooting and Maintenance

The Karavan electrical system is quite trouble-free especially with the use of the automotive type wire harness that we use. This eliminates shorts in the system due to bad or corroded connections. We suggest however that you use the following precautions for trouble-free trailering:

1. Disconnect the tongue harness from the towing vehicle before backing the trailer into the water. This will eliminate the bulbs from lighting while submerged in the water. Lighting submerged light bulb will cause it to burn out. (This is not necessary if your unit is equipped with waterproof taillights and rear cluster).
2. Carry a spare taillight bulb #1157, which is the large bulb in the taillight. The smaller bulb in the taillight for the sidelight is #57, and is also used in the rectangular amber sidelight.
3. Once a year remove the light lenses and spray or coat the metal components with either WD40 or CRC. A light coat of petroleum jelly also works quite well so that the metal doesn't rust and makes water run right off.
4. Make sure your towing vehicle's electrical system is sufficient to handle the extra load required to power your trailer lights. Check with your local automotive dealer for specifications and any options available to increase the electrical capacity.
5. In order to insure a positive ground connection between the trailer and the towing vehicle, it is important that the white ground wires are secured properly to both the trailer and the towing vehicle. A poor ground connection will cause the taillights to blink and not function properly.



Load-Carrying Capacity

The serial tag will show the Gross Vehicle Weight Rating (GVWR) which is the load-carrying capacity plus the weight of the trailer itself. NOTE: This trailer is equipped to meet applicable Federal safety standards. Check local and state requirements regarding brakes and any additional equipment that may be required. Any modifications or additions including load equalizing hitches, without written factory consent; usage in an abnormal manner including overloading voids all manufacturers warranties and liability.

Towing Your Trailer

Caution!

Check the following items each time before towing trailer.

1.	Be sure all parts, bolts and nuts are tight.	6.	Do not exceed trailer capacity.
2.	Secure load to trailer with BIA approved tiedowns.	7.	Be sure all lights are operating and are disconnected before backing into water.
3.	Check tire pressure when tire is cold. Check and adjust wheel bearings if necessary after first 50 miles of use.	8.	Coupling ball - make sure you are using the size marked on the trailer coupling and coupling must be securely latched to the ball.
4.	Inspect and repack wheel bearing at least twice a year and before storing.	9.	Cross safety chains under tongue and secure to towing vehicle.
5.	Check that the Bed Locking Pin is in place.	10.	Check brake operation.

5KTBS1914PX000003



KHU-2990-72-12

5KTBS1914PX000003



KHU-2990-72-12

MFD BY/FABRIQUE PAR - KARAVAN TRAILERS LLC									
DATE: 12/21/2022				MADE IN USA			JOB# J000000001		
ALL AXLES					COLD INFL. MAX. LOAD				
GVWR / PNBV		CAWR / PNBZ		TIRE/PNEU		PRESSURE		CARRYING CAP	
KG	LBS	KG	LBS			KPA	PSI	KG	LBS
1996	4400	1996	4400	ST175R80D13	345	50	1588	3500	Rm1
1996	4400	1996	4400	ST175R80D13	345	50	1588	3500	Rm2
1996	4400	1996	4400	ST175R80D13	345	50	1588	3500	Rm3
1996	4400	1996	4400	ST175R80D13	345	50	1588	3500	Rm4

THIS VEHICLE CONFORMS TO ALL APPLICABLE U.S. FEDERAL MOTOR VEHICLE SAFETY STANDARDS (FMVSS) IN EFFECT ON THE DATE OF MANUFACTURE SHOWN ABOVE. THIS VEHICLE CONFORMS TO ALL APPLICABLE STANDARDS PRESCRIBED UNDER THE CANADIAN MOTOR VEHICLE SAFETY REGULATIONS IN EFFECT ON THE DATE OF MANUFACTURE SHOWN ABOVE.

CE VEHICULE EST CONFORME A TOUTES LES NORMES QUI LUI SONT APPLICABLES EN VERTU DU REGLEMENT SUR LA SECURITE DES VEHICULES AUTOMOBILES DU CANADA EN VIGUEUR A LA DATE DE SA FABRICATION.

KHU-2990-72-12 5KTBS1914PX000003



US/Utility Square Tube

TIRE AND LOADING INFORMATION
 RENSEIGNEMENTS SUR LES PNEUS ET LE CHARGEMENT
 The weight of cargo should never exceed 1996 KG 4400 LBS
 Le poids du chargement ne doit jamais dépasser 1996 KG 4400 LBS

KARAVAN

TIRE/PNEU	SIZE	COLD TIRE PRESSURE	SEE OWNER'S
	DIMENSIONS	PRESSION DES PNEUS A FROID	MANUAL FOR ADDITIONAL INFORMATION
FRONT	ST175R80D1	345 KPA	VOIR LE MANUEL DE L'USAGER POUR PLUS DE RENSEIGNEMENTS
AVANT	3	50 PSI	
OPTION	ST175R80D1	345 KPA	
OPTION	3	50 PSI	
OPTION	ST175R80D1	345 KPA	
OPTION	3	50 PSI	
OPTION	ST175R80D1	345 KPA	
OPTION	3	50 PSI	

WARNING:

Fishtailing caused from improper tongue weight on the tow vehicle hitch ball can cause loss of control of the tow vehicle and result in serious injury or property damage.



TIRE AND LOADING INFORMATION
RENSEIGNEMENTS SUR LES PNEUS ET LE CHARGEMENT
 The weight of cargo should never exceed 1996 KG 4400 LBS
 Le poids du chargement ne doit jamais dépasser 1996 KG 4400 LBS

KARAVAN

TIRE/ PNEU	SIZE DIMENSIONS	COLD TIRE PRESSURE PRESSION DES PNEUS A FROID		SEE OWNER'S MANUAL FOR ADDITIONAL INFORMATION VOIR LE MANUEL DE L'USAGER POUR PLUS DE RENSEIGNEMENTS
FRONT AVANT	ST175/80D1 3	345 50	KPA PSI	
OPTION OPTION	ST175/80D1 3	345 50	KPA PSI	
OPTION OPTION	ST175/80D1 3	345 50	KPA PSI	
OPTION OPTION	ST175/80D1 3	345 50	KPA PSI	

5KTB51914PX000003

Weight Distribution

Establishing a trailer with the proper GVWR is very important. But once that has been established and you have the load on the trailer it is equally important that you have the proper distribution of the weight on the trailer. By that we mean you should have 5 to 10% of the total weight of your loaded trailer on the hitch coupler which is called tongue weight. This should be checked when the tongue is parallel to the ground. A bathroom scale can be used to determine this, or go to a truck scale.

EXAMPLE: The gross vehicle weight of trailer and load is 2,000 pounds. The tongue weight should not be less than 100 pounds nor more than 200 lbs.

Too light of tongue weight can cause the trailer to “fishtail” (sway from side to side) as you travel down the highway. This creates excessive strains on the towing vehicle, hitch and also the trailer itself. It can very easily cause an accident. To adjust for too light tongue weight the axle/axles must be moved backward on the trailer allowing more weight to be carried on the tongue. This is accomplished by loosening the U-bolts on most models. Adjustments should be made until the tongue weight falls within the 5 to 10% recommended range.

If only a slight weight adjustment is required it’s possible you may be able to move gear to compensate the difference. Some towing vehicles require less tongue weight than others.

The 5 to 10% guide lines will hold quite true to form until you get into larger size loads anywhere from 4,000 pounds on up. At this point it becomes necessary to strike a happy medium of sufficient tongue weight to tow properly and yet not too much tongue weight as to create undue stress on the towing vehicle, hitch and hitch coupler. Check hitch rating to be sure of it’s capacity or when buying a hitch make sure it will carry the load.

The weight-distribution hitch may be recommended to you by the dealer for heavier units. If this type system is installed all responsibilities will become those of the owner of the unit, not those of Karavan Trailers, LLC.

Listed are several items you must consider should you install this type system. First off, make sure they are installed properly.

Care should be used so that they are not overloaded to the point the undue strain is applied to both the trailer and towing vehicle. This type system dampens the action of the surge hydraulic brake systems thus causing the brakes either not to be applied as soon as possible or may cause them to be partially applied at all times especially when being towed. This leads to overheated brakes plus excessive brake shoe wear. It may also lead to bearing failures because the heat build up will disintegrate the grease in the bearings.

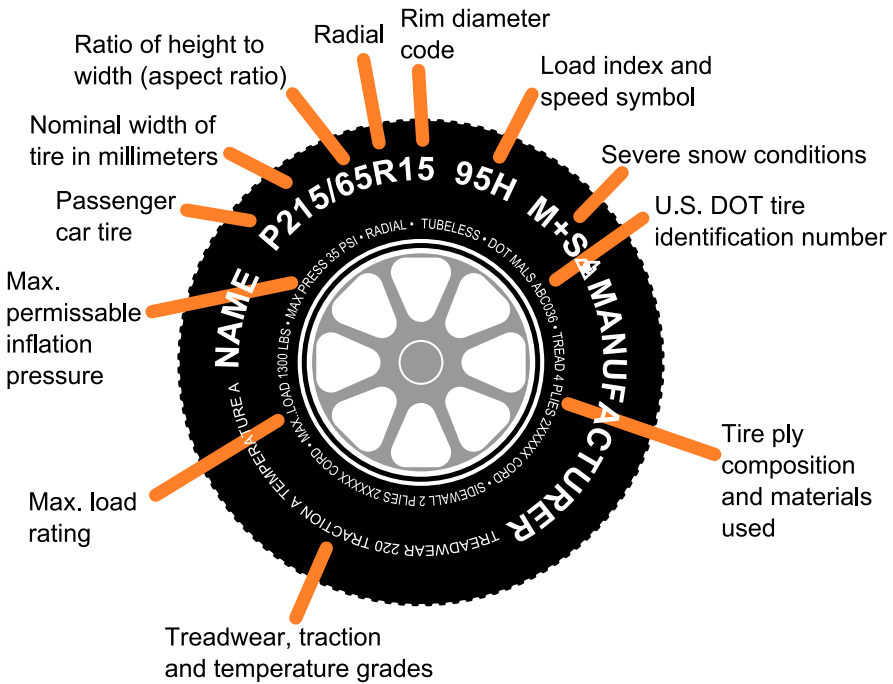

Wheel Size

Karavan uses different wheel sizes on its trailer line as listed in the chart below. Spare wheels may be purchased from Karer and the towing vehicle. A poor ground connection will cause the taillights to blink and not function properly.avan dealer or else an automotive supply house with the given information. Read the numbers from the tire and count lug bolts to determine rim size.

Size	Bolt Circle	Off Set	Recommended Torque (ftlbs)	
			Steel	Aluminum
12"	4-4 or 5-4.5	0.00	50-75	95-105
13"	4-4 or 5-4.5	0.00	50-75	95-105
14"	5-4.5	0.00	90-120	110-120
15"	5-4.5	0.00	90-120	110-120
15"	6-5.5	0.00	90-120	110-120
16" (1/2" Stud)	6-5.5	0.00	90-120	110-120
16" (9/16" Stud)	8-6.5	0.00	90-120	125-130
17.5" (9/16" Stud)	8-6.5	0.00	N/A	125-130
17.5" (5/8" Stud)	8-6.5	0.00	275-325 (Flango	150

Register Your Trailer

Thanks for choosing Karavan and welcome to the family. Register your product now with the QR code below to activate your warranty.



Make a Claim

Fill out a warranty form and send your claim details to Karavan by using the QR code below. We'll work to resolve your claim as soon as possible.



View Warranty Policy

We build exceptional quality and durability into every product we produce. Use the QR code to download our warranty policy to learn about our warranty coverage.

